

# ERV OIL-SEALED ROTARY VANE VACUUM PUMPS

ERV16-300

 **EDWARDS**

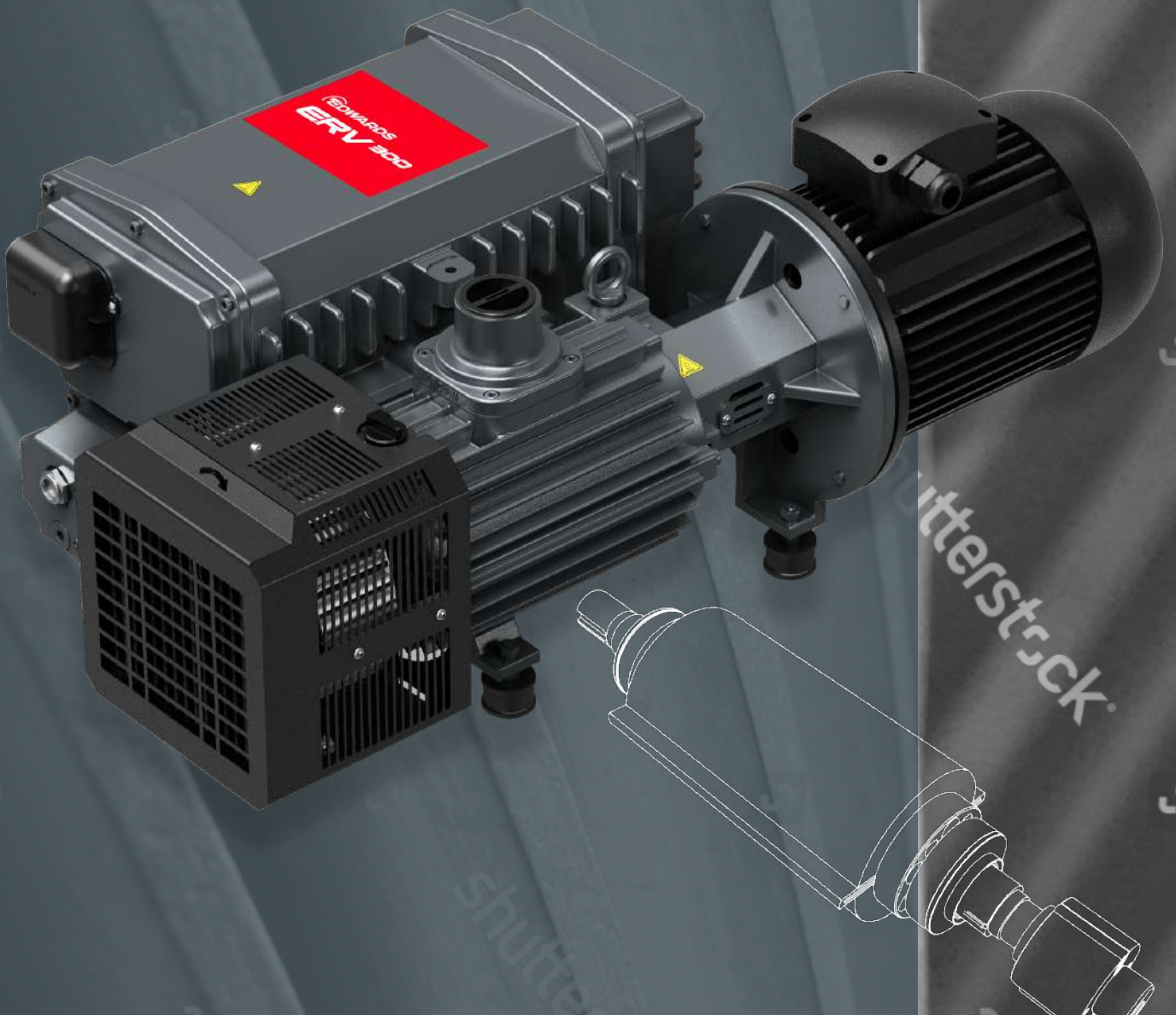





## EDWARDS THE PARTNER OF CHOICE

Edwards is a world leader in the design, technology and manufacture of vacuum pumps for industrial applications with over 100 years' history.

We believe in delivering results that bring value to our customers by using our breadth of industry experience to identify and apply solutions. Using the most innovative and up-to-date modelling techniques, we can optimise the pumping configuration for customers to provide a system design giving the maximum performance in the most reliable and cost-effective way.

## ERV SERIES

The Edwards ERV series are a range of robust and compact single-stage, oil sealed rotary vane vacuum pumps. These "Made in India" vacuum pumps offer high reliability, proven performance, these air-cooled vacuum pumps are an ideal solution to suit a broad range of requirements.

The series delivers consistent pumping performance and high pumping speed at low pressures provides an ideal solution for a wide range of applications. This pump with its ease of service ensures minimum maintenance and hence leads to allow overall life cycle cost.

The compact design of the pump with minimal vibration, quiet operation and lower oil consumption minimises environmental impact and leads to lower emissions.

### Technology you can rely on



High pumping speed at low pressures



Gas ballast valve as standard



Integral anti-suck back valve



Exhaust mist filter with built-in bypass valve



Low oil-consumption



Air-cooled





## RANGE OF PUMPS TO SUIT EVERY NEED



ERV16



ERV40



ERV65



ERV100



ERV200



ERV300

## APPLICATIONS



### Power industry

- Transformer/capacitor drying
- Oil purification

### Composites

- RTM light / resin infusion
- Autoclaves

### Utility vacuum

- Pick and place
- Conveying

### Resin impregnation

### Vacuum drying

### Pharmaceutical and hospitals

### Thermoforming



## TECHNICAL SPECIFICATIONS

Particulars	Unit	ERV16	ERV40	ERV65	ERV100	ERV200	ERV300
Nominal pumping speed @ 50Hz	m <sup>3</sup> /h (L/min)	17 (183)	43 (717)	65 (1083)	102 (1700)	192 (3200)	300 (5000)
Ultimate vacuum (Total pressure)	Gas ballast closed in mbar (Torr)	≤ 0.3 (0.225)	≤ 0.1 (0.075)	≤ 0.1 (0.075)	≤ 0.1 (0.075)	≤ 0.1 (0.07)	≤ 0.3 (0.225)
	Gas ballast open in mbar (Torr)	≤ 1.5 (1.125)	≤ 1.5 (1.125)	≤ 1.5 (1.125)	≤ 1.5 (1.125)	-	-
	Small gas ballast in mbar (Torr)	-	-	-	-	≤ 0.8 (0.6)	≤ 0.8 (0.6)
	Standard gas ballast in mbar (Torr)	-	-	-	-	≤ 1.5 (1.125)	≤ 1.8 (1.35)
	Big gas ballast in mbar (Torr)	-	-	-	-	≤ 2 (1.5)	≤ 2.5 (1.87)
Water vapour pumping capacity	kg/h	0.3	0.9	1.4	2.2	1.5, 2.5, 4*	2.4, 4.5, 6*
Water vapour tolerance	mbar	40	40	40	40	20, 30, 40*	20, 30, 40*
Nominal power rating at 50Hz	kW(HP)	0.55 (0.75)#	1.1 (1.5)	1.5 (2)	2.2 (3)	3.7 (5)	5.5 (7.5)
Motor rotational speed at 50Hz	rpm	1500	1000	1500	1500	1500	1500
Weight	kg	29	55	59	80	139	193
Inlet connection		G 3/4" F	G 1 1/4" F	G 1 1/4" F	G 1 1/4" F	G 2" F	G 2" F
Outlet connection		G 3/4" F	G 1 1/4" F	G 1 1/4" F	G 1 1/4" F	G 2" F	G 2" F
Oil capacity	L	1	1.8	1.8	2.5	8	9.5
Recommended oil	Standard	Ultragrade Performance 70					
Power supply		Three Phase 415V, 50Hz	Three Phase 415V, 50Hz				

\* Small, standard and big gas ballast # Motor variants available

## PERFORMANCE CURVES

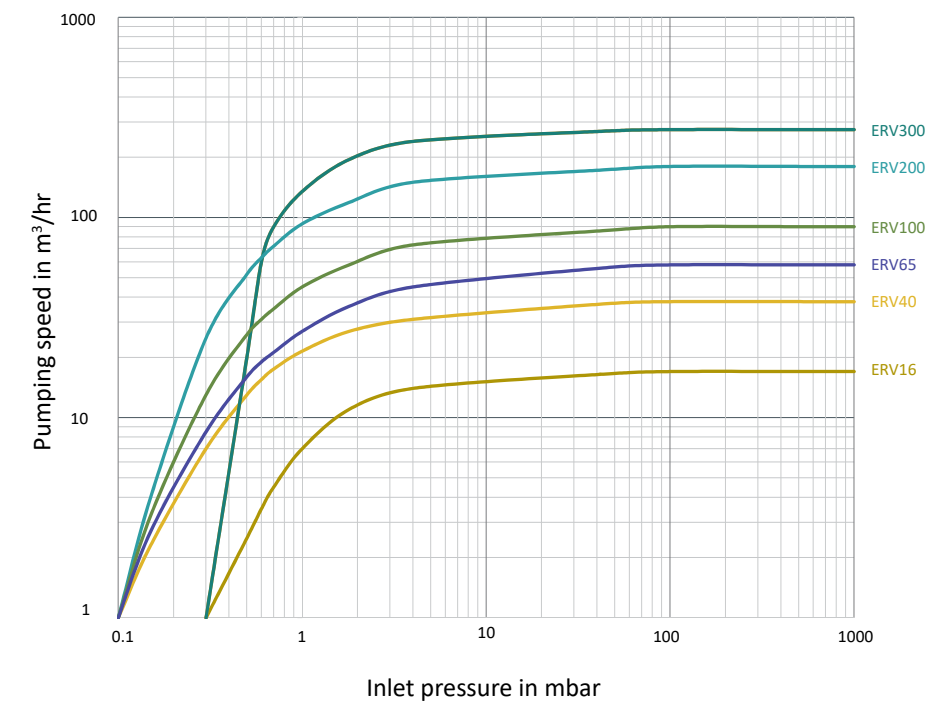

## DIMENSIONS

### ERV16

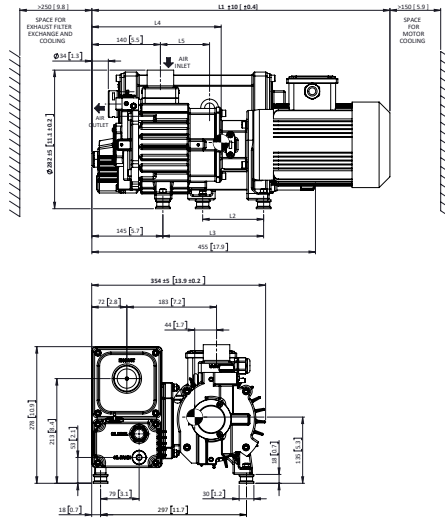

### ERV40

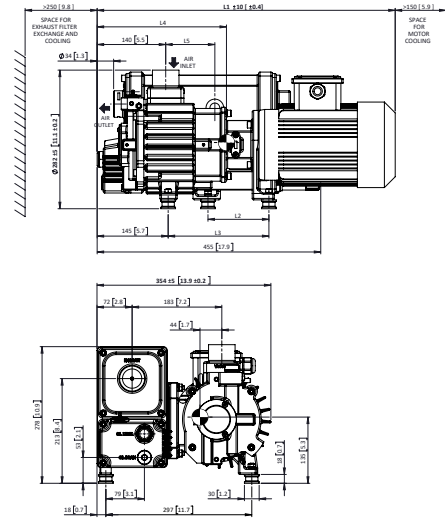

### ERV65

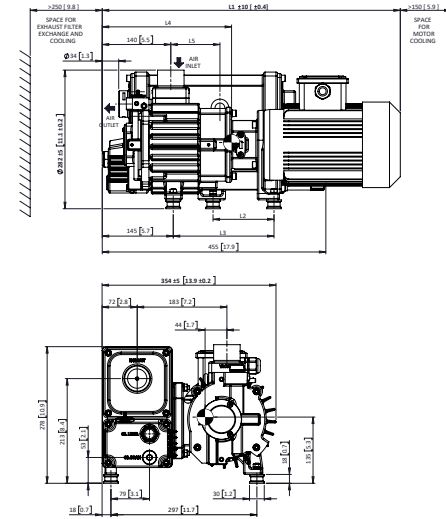

### ERV100

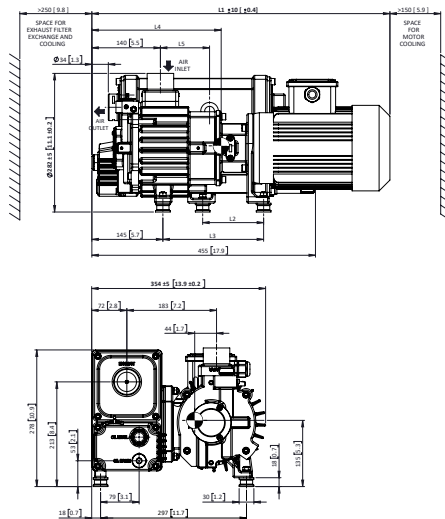

### ERV200

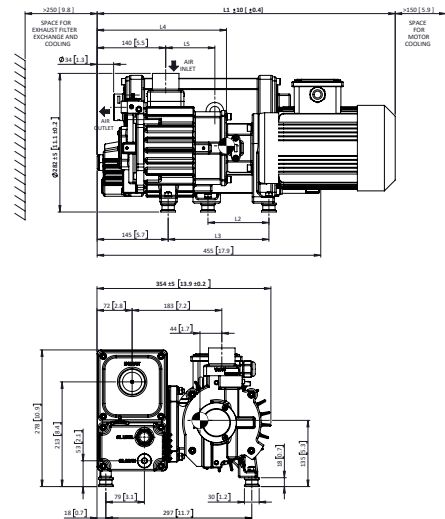

### ERV300

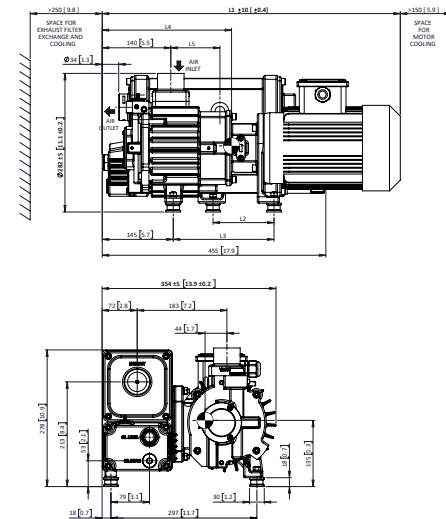

## ORDERING INFORMATION

Part number	Pump description	Motor
A32084938	ERV16 - 415V 50Hz 3Ph IE2	with IE2 motor
A32104938	ERV40 - 415V 50Hz 3Ph IE2	with IE2 motor
A32304938	ERV65 - 415V 50Hz 3Ph IE2	with IE2 motor
A32404938	ERV100 - 415V 50Hz 3Ph IE2	with IE2 motor
A32504938	ERV200 - 415V 50Hz 3Ph IE2	with IE2 motor
A32604938	ERV300 - 415V 50Hz 3Ph IE2	with IE2 motor
A32084939	ERV16 - 415V 50Hz 3Ph IE3	with IE3 motor
A32104939	ERV40 - 415V 50Hz 3Ph IE3	with IE3 motor
A32304939	ERV65 - 415V 50Hz 3Ph IE3	with IE3 motor
A32404939	ERV100 - 415V 50Hz 3Ph IE3	with IE3 motor
A32504939	ERV200 - 415V 50Hz 3Ph IE3	with IE3 motor
A32604939	ERV300 - 415V 50Hz 3Ph IE3	with IE3 motor

## ACCESSORIES

Part number	Description	
2031000576	Inlet dust filter polyester ERV16	Inlet dust filter with polyester filter element
2031003575	Inlet dust filter polyester ERV40-65-100	Inlet dust filter with polyester filter element
2031005575	Inlet dust filter polyester ERV200-300	Inlet dust filter with polyester filter element
2031000578	Inlet dust filter metal ERV16	Inlet dust filter with stainless steel mesh
2031003577	Inlet dust filter metal ERV40-65-100	Inlet dust filter with stainless steel mesh
2031005577	Inlet dust filter metal ERV200-300	Inlet dust filter with stainless steel mesh

## SERVICE AND SUPPORT

Our expertise is in vacuum technology. We have been in the business since 1919 and our knowledge runs deep. We design, develop and manufacture vacuum equipment to the highest standards.

But it's not just the technology. With a global installed base of 750,000 pumps, we understand how vacuum pumps and systems perform in real life. We know how to get the best from our products, whatever the application. We know how to look after them. That's why a large section of our expert workforce is dedicated to service and support.

Our service solutions include; on-site service, repairs and exchange, and quality spares. All built on our world-class technical know-how and backed by our sophisticated logistics and supply chain infrastructure.





Publication Number: 0000 000 0 00  
© Edwards Limited 11.2022. All rights reserved  
Edwards and the Edwards logo are trademarks of  
Edwards Limited.

Whilst we make every effort to ensure that we  
accurately describe our products and services,  
we give no guarantee as to the accuracy or  
completeness of any information provided in  
this brochure.

Edwards Ltd., registered in England and Wales  
No. 6124750, registered office: Innovation Drive,  
Burgess Hill, West Sussex, RH15 9TW,  
United Kingdom.